



# Installation Instructions

**Thank you for purchasing this anti-sway bar kit. Please read through these instructions before installation.**

## Rear Anti-Sway Bar Kit for the Monaco Diplomat

part #1169-209

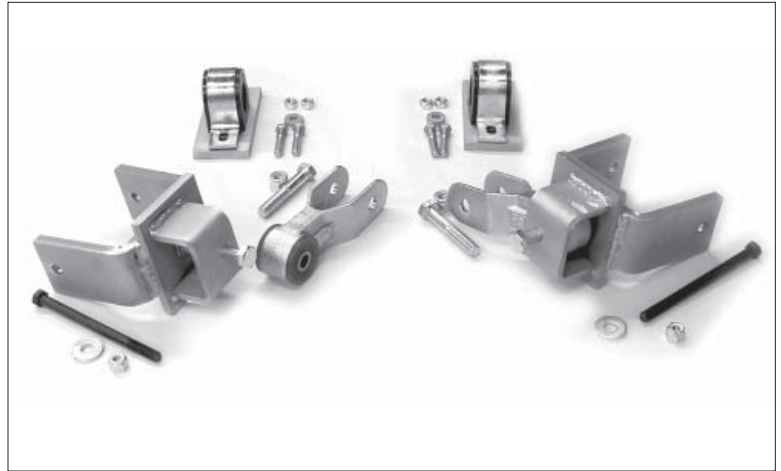

## INTRODUCTION

Thank you for purchasing this anti-sway bar kit. This kit is designed to improve the handling characteristics of your motorhome by reducing the body roll and balancing the weight transfer during cornering. The anti-sway bar kit is engineered for long life and trouble-free performance. For maximum suspension control, use this kit along with our front anti-sway bar kit.

All the hardware needed for installation is included in this kit. Refer to the PARTS LIST in these instructions to identify the parts.

## SUGGESTED TOOLS

The following tools are suggested to complete the installation procedures:

- General hand tools
- Torque wrench
- Drill motor
- 7/16" drill bit

### **Free Lifetime Warranty**

*You must accurately and completely fill out and mail the product registration card within thirty (30) days from the date of purchase to qualify for your warranty.*

*Your product registration is an important record for Source Engineering, Inc. to keep in touch with you. It also enables us to expedite any future claim, update or recall that may arise concerning our products.*

# PARTS LIST

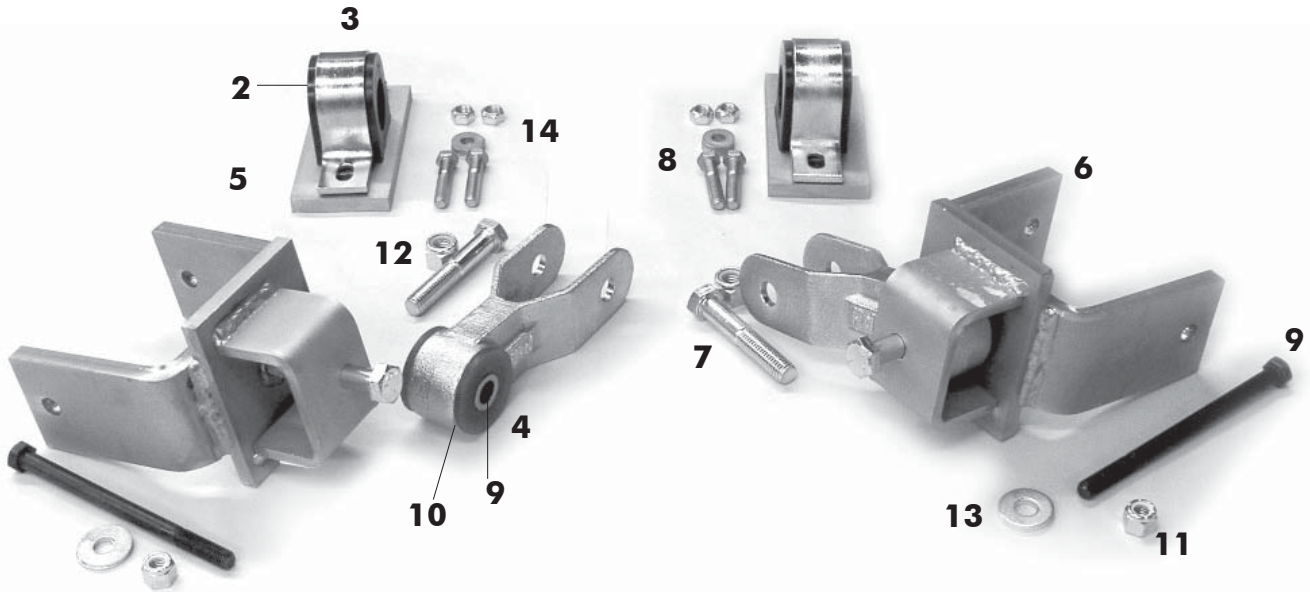

Part #1169-209

Part #	Description	Qty	
1. 580083-00	Rear sway bar, 1-5/8"	1	*
2. 205222-10	Poly bushing, 1-5/8" split	2	
3. B141	Bushing clamp	2	
4. B209	Shackle assembly, rear	2	
5. B457	Bracket, 6" x 3 x 3/8"	2	
6. B458	Bracket shackle hanger	2	
7. 350163-00	Bolt, 5/8" x 3-1/2"	4	
8. 350076-80	Bolt, 7/16" x 2"	4	
9. 205503-00	Sleeve	2	
10. 205209-00	Poly Bushing	4	
11. 350111-80	Bolt, 1/2" x 7"	2	
12. 350256-02	Locknut, 7/16"	4	
13. 350259-00	Nyloc nut, 1/2"	2	
14. 350263-00	Nyloc nut, 5/8"	2	
15. 350308-00	Washer, 1/2"	4	
16. 350304-80	Washer, 7/16"	8	
17. 400011-30	AQUALUBE Grease	1	

\* not shown

# INSTALLATION

The following instructions must be followed in the order listed to ensure a proper installation and to preserve the Source Engineering, Inc. warranty.

**1. Locate the holes for the anti-sway bar mounting brackets.**

Find the chassis cross member above the rear H frame, behind the rear axle. Measure six inches toward the rear of the chassis to locate the front hole of the anti-sway bar clamp bracket. Use the clamp bracket to locate and mark the rear hole. Drill 7/16" size holes in the frame rail. Do this on both sides.

**2. Prepare and install the anti-sway bar.**

Locate the D-shaped anti-sway bar bushings. Lubricate the inside with the supplied grease. Rotate the anti-sway bar up and into its final position. Install the bushings onto the anti-sway bar. Slide the bushing clamps over the bushings. Using the hardware provided, mount the bar to the frame rail using the backing plate on top of the frame rail. See Figure 2.

**3. Connect the shackles to the H-frame hangers B458.**

Examine the frame hangers, and note that the shackle mounting bolt is offset to one side. Insert the shackle from the side with the narrow gap. See Figure 3. Bolt it together using the hardware provided. Do this for both sides.

**4. Connect the shackles to the sway bar.**

Slip the arms of H-frame hanger (B458) over the H-frame. Using the bolts provided, connect the shackles to the anti-sway bar arms. Do not tighten at this time.

**5. Locate the final position of the frame hanger brackets.**

With the chassis at normal ride height, position the hanger brackets so that the shackle is positioned straight up and down. Now, tighten the bolts to fasten the hanger bracket to the H-frame.

**6. Tighten all fasteners (Including the shackle to anti-sway bar bolts) and test drive the vehicle.**

Listen for any unusual noises. Re-inspect the installation and re-check the fasteners.

## **WARNING**

After road testing, re-check all fasteners for proper tightness — if a fastener has worked loose or fallen off, re-tighten or replace it. Without all kit components properly tightened or in place, the anti-sway bar will not stabilize the vehicle at full capacity, which may cause reduced cornering ability or other reductions in vehicle handling or performance.

Failure to follow these instructions may result in property damage, personal injury or even death.

## **WARNING**

### **The anti-sway bar is not a load-bearing component**

Do not tow or hoist the vehicle using the anti-sway bar or its mounting brackets as attachment points. The anti-sway bar is not designed to carry the weight of the vehicle and may collapse, which will damage the anti-sway bar components, the suspension, or other components. The vehicle will detach or fall, which may cause severe personal injury.

Failure to follow these instructions may result in property damage, personal injury or even death.

# INSTALLATION

**Figure 1**

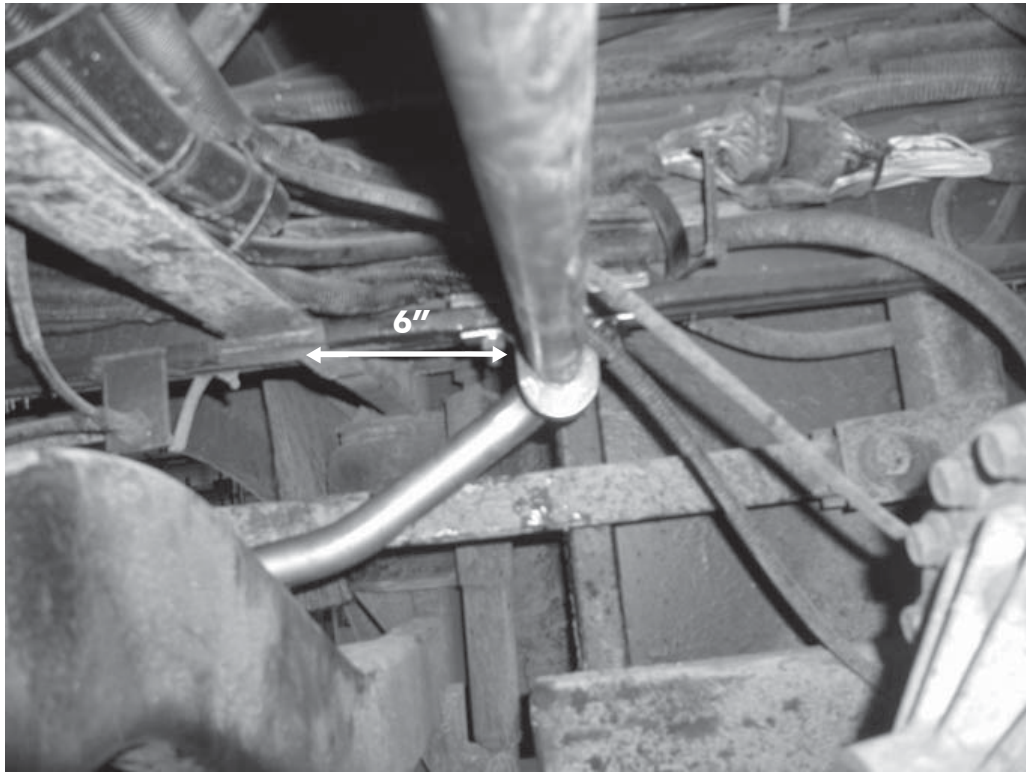

**Figure 2**



**Rear of Coach** →



# INSTALLATION

**Figure 3, 4**

**Note: pay careful attention to this figure for correct installation.**

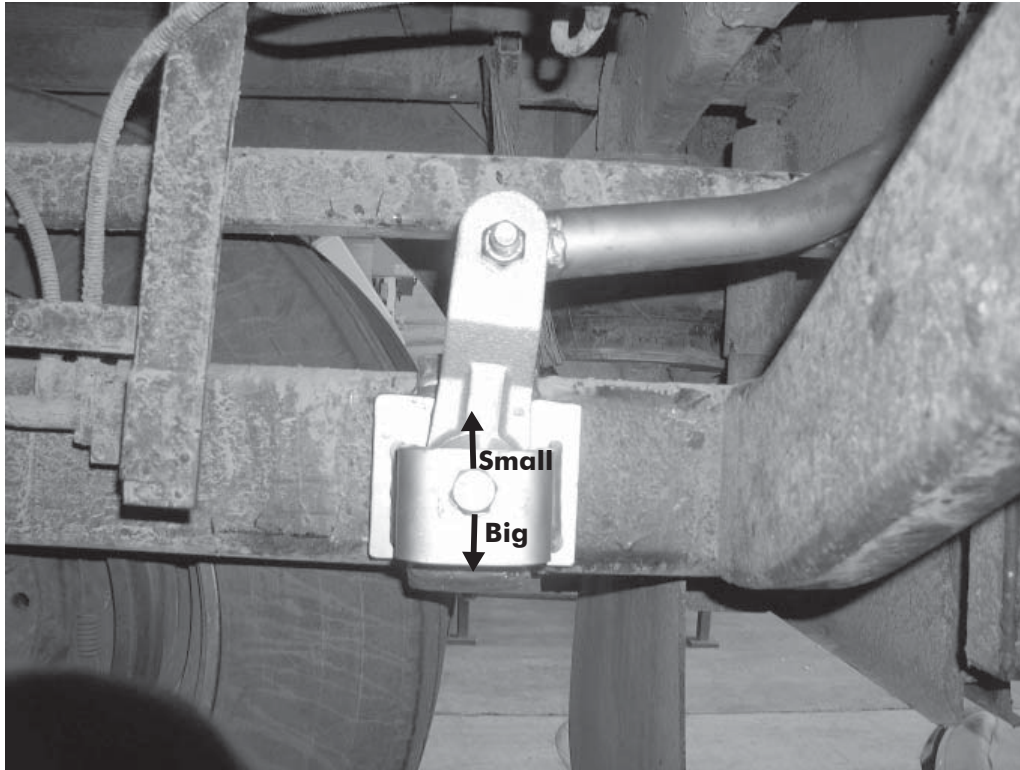

**Figure 5**

**As close to straight up and down as possible**

